

DESIGN A

UPPER LEVEL

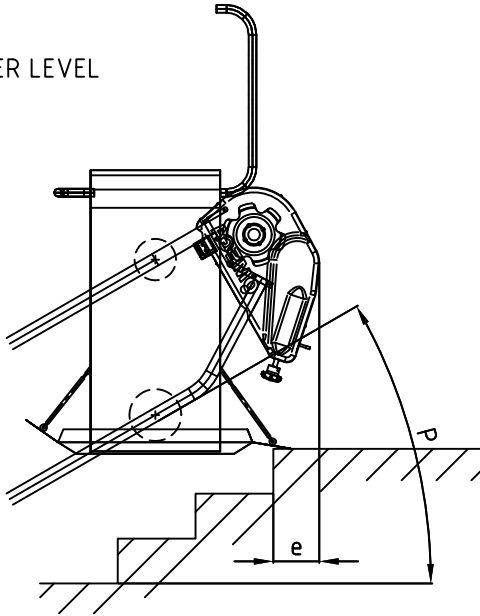

DESIGN B

UPPER LEVEL

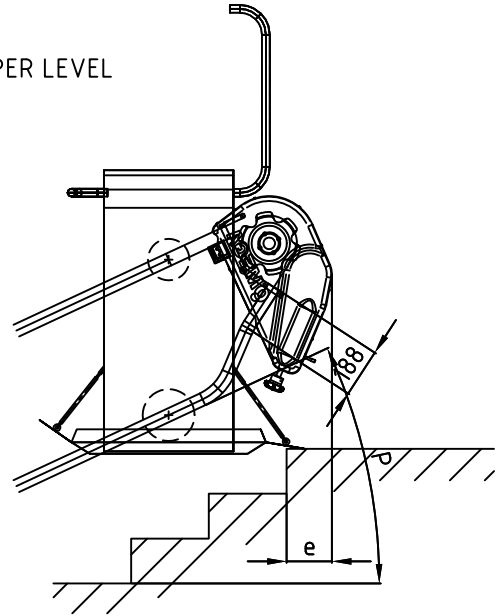

DESIGN C
UPPER LEVEL

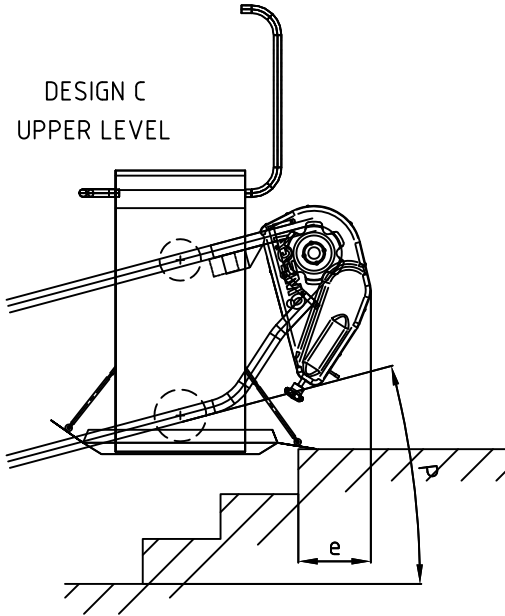

NEW DRIVE UNIT

C	0°	365	315	290	240	156
	15°	265	215	190	140	33
	22°	270	220	195	145	42
B	23°	160	110	85	35	-75
	25°	160	110	85	35	-75
	27°	160	110	85	35	-75
A	28°	160	110	85	35	-73
	30°	160	110	85	35	-73
	35°	160	110	85	35	-73
	40°	160	110	85	35	-73
	45°	160	110	85	35	-73
DESIGN	P	e	e	e	e	e
	RAIL ANGLE	L = 750	L = 850	L = 900	L = 1000	L = 1250

Waiver: This data sheet is for guidance only and can not be used for proper working drawings. Please contact supplier for particular details before proceeding. Owing to our policy of continual improvement we reserve the right to after specifications and dimensions without prior notice.

IF MOTOR IS IN POS. 1
DIMENSION E1 IS VALID.
IF MOTOR IS IN POS.2
DIMENSION E IS VALID.

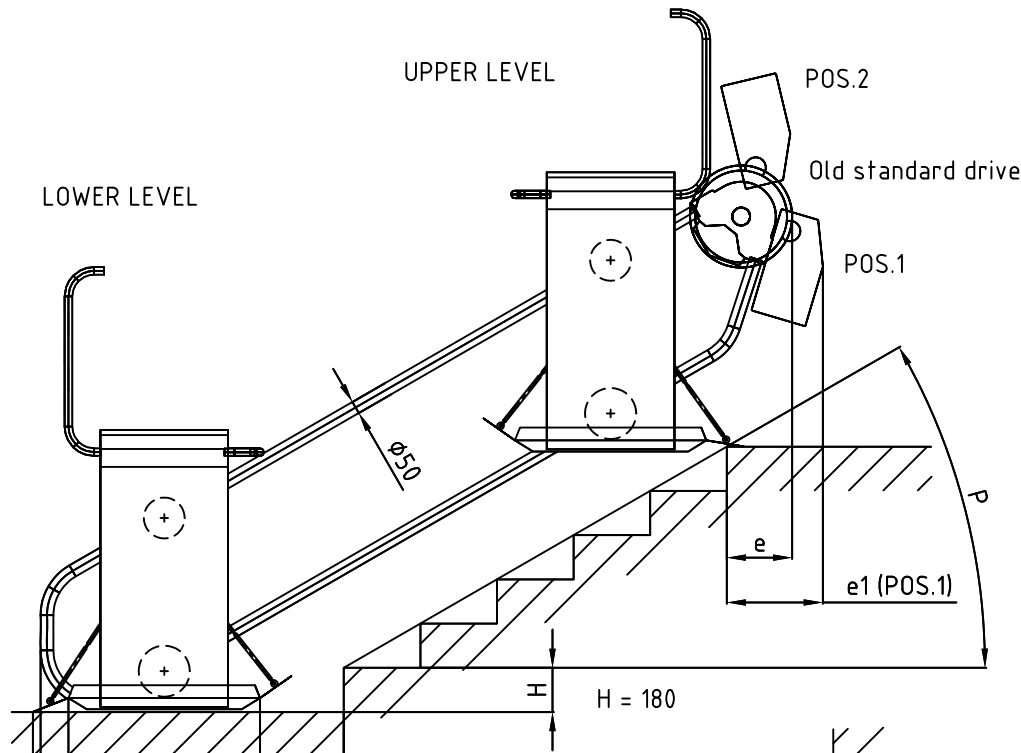

FREE STANDING 205
WALL MOUNTED 140
FREE STANDING 143
WALL MOUNTED 81

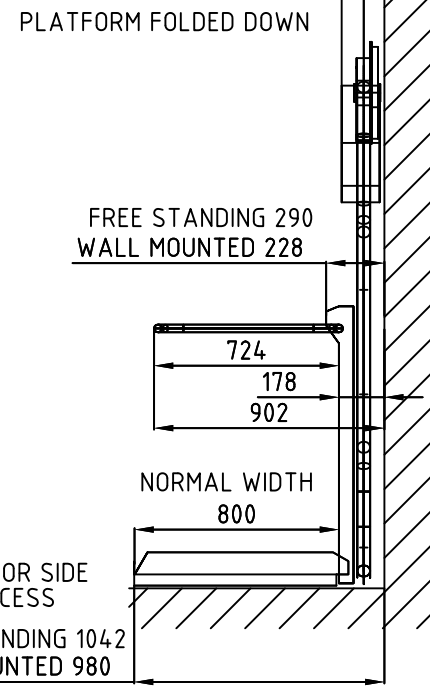
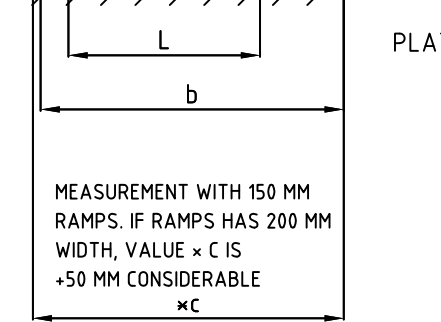

25°	0,5 L + 880	L + 541
30°	0,5 L + 824	L + 479
35°	0,5 L + 753	L + 440
37°	0,5 L + 718	L + 411
47°	0,5 L + 634	L + 354
P	b	*c
RAIL ANGLE	L - SPECIAL PLATFORM LENGTH	

25°	1255	1291	234	399	1305	1391	234	399	1330	1441	234	399	1380	1541	280	399	1517	1780	234	399
30°	1199	1229	253	376	1249	1229	253	376	1274	1379	253	376	1324	1479	253	376	1437	1719	253	376
35°	1128	1190	212	361	1178	1190	212	361	1203	1340	212	361	1253	1440	212	361	1369	1676	212	361
37°	1093	1163	220	357	1143	1263	220	357	1168	1313	220	357	1218	1413	220	357	1343	1661	220	357
40°	-	-	260	350	-	-	260	350	-	-	260	350	-	-	260	350	-	-	260	350
45°	-	-	310	338	-	-	310	338	-	-	310	338	-	-	310	338	-	-	310	338
47°	1021	1108	159	325	1071	1208	159	325	1096	1258	159	325	1146	1358	159	325	1258	1604	159	325
P	b	*c	e	e1	b	*c	e	e1	b	*c	e	e1	b	*c	e	e1	b	*c	e	e1
RAIL ANGLE	L = 750				L = 850				L = 900				L = 1000				L = 1250			

Waiver: This data sheet is for guidance only and must not be used for proper working drawings. Please contact supplier for particular details before proceeding. Owing to our policy of continual improvement we reserve the right to after specifications and dimensions without prior notice.

90° CURVE
WALL

IF NOMINAL VALUE IS SMALLER
THEN 81 MM, IN UPPER PIPE
SURROUNDING WALL EDGE
MUST BE CUTTED

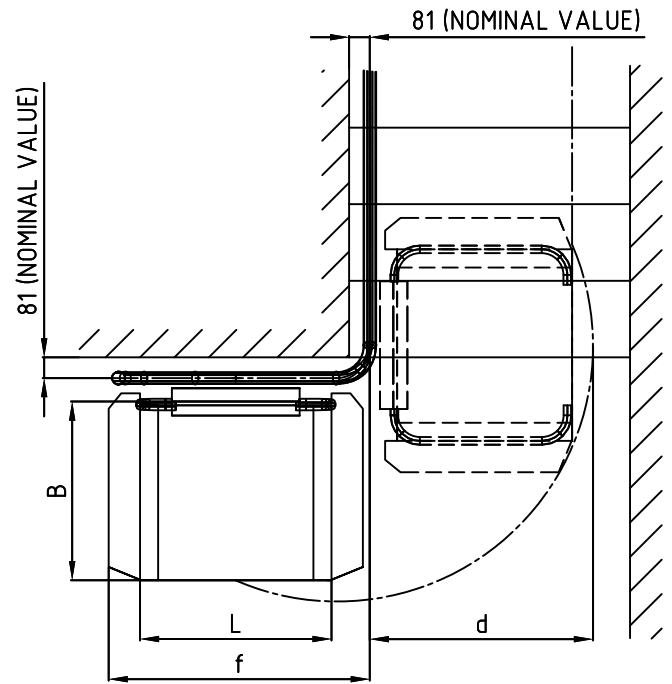
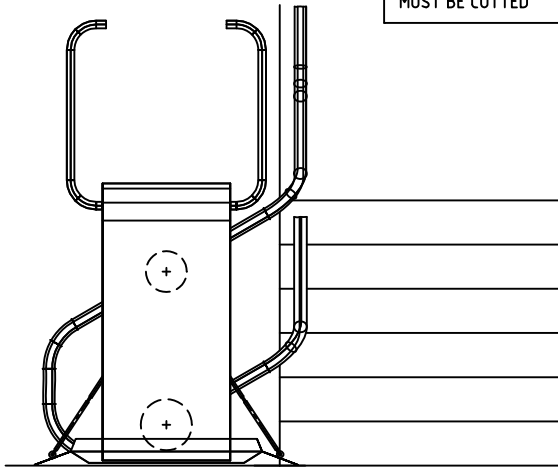

180° CURVE
WALL BETWEEN RAIL

IF NOMINAL VALUE IS SMALLER
THEN 81 MM, IN UPPER PIPE
SURROUNDING WALL EDGE
MUST BE CUTTED

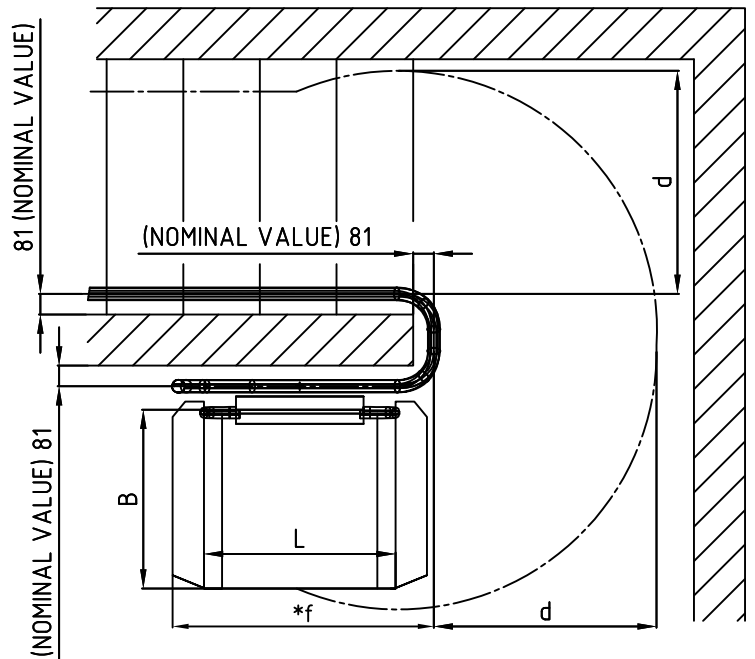
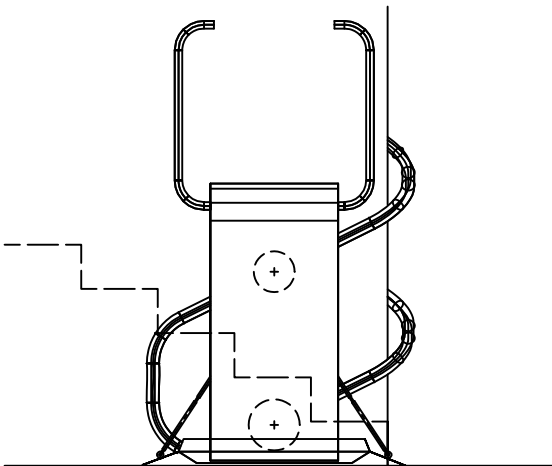

PLATFORM LENGTH L	ACCESS RAMPS	PLATFORM WIDTH B										*f
		600	640	670	700	740	750	770	800	900	1000	
		d										
750	200	789	823	848	874	909	917	935	962	1054	1149	1150
850	200	816	849	874	899	942	950	959	985	1074	1163	1250
900	200	832	864	889	914	947	955	973	998	1085	1174	1300
1000	200	862	894	918	942	975	983	1000	1023	1110	1197	1400
1250	200	930	960	985	1007	1046	1054	1060	1085	1167	1251	1650

*f is valid for ramp 200mm.
For ramp 150mm can be
100mm shorter

Waiver: This data sheet is for guidance only and must not be used for proper working drawings. Please contact supplier for particular details before proceeding. Owing to our policy of continual improvement we reserve the right to after specifications and dimensions without prior notice.

180° CURVE WITHOUT WALL

IF HANDRAIL ON STAIRCASE
EXIST, RAIL CAN BE FIXED
THROUGH HANDRAIL

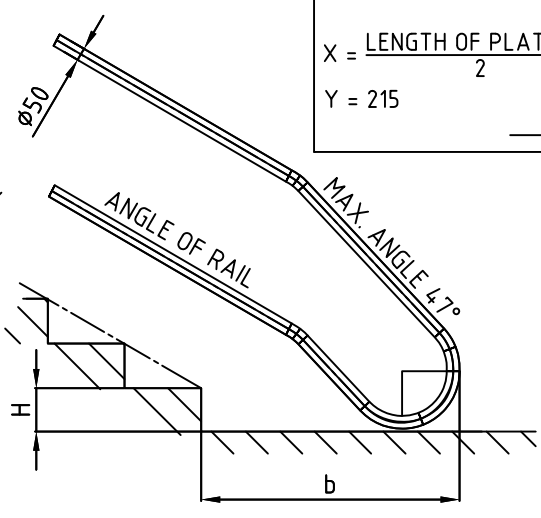
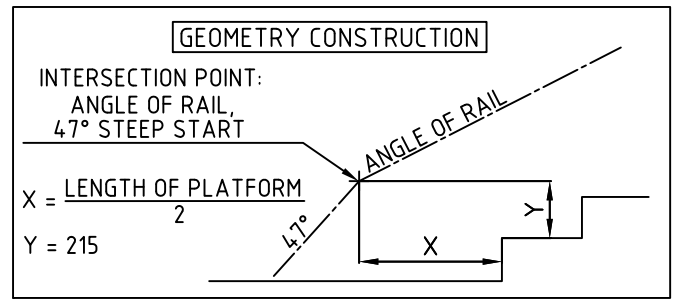
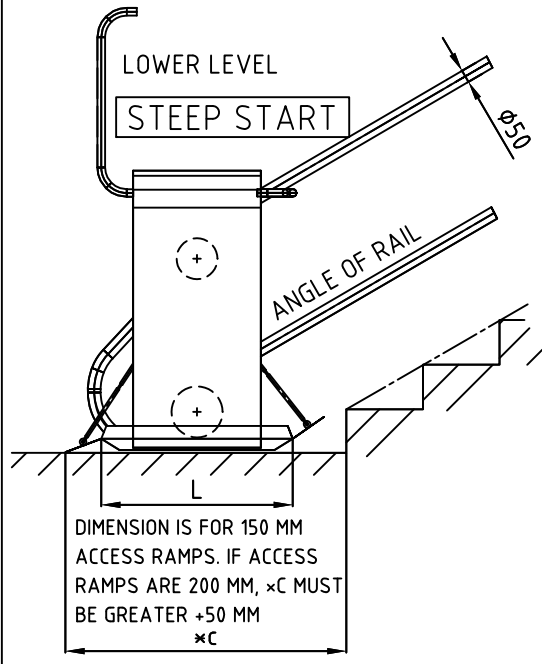
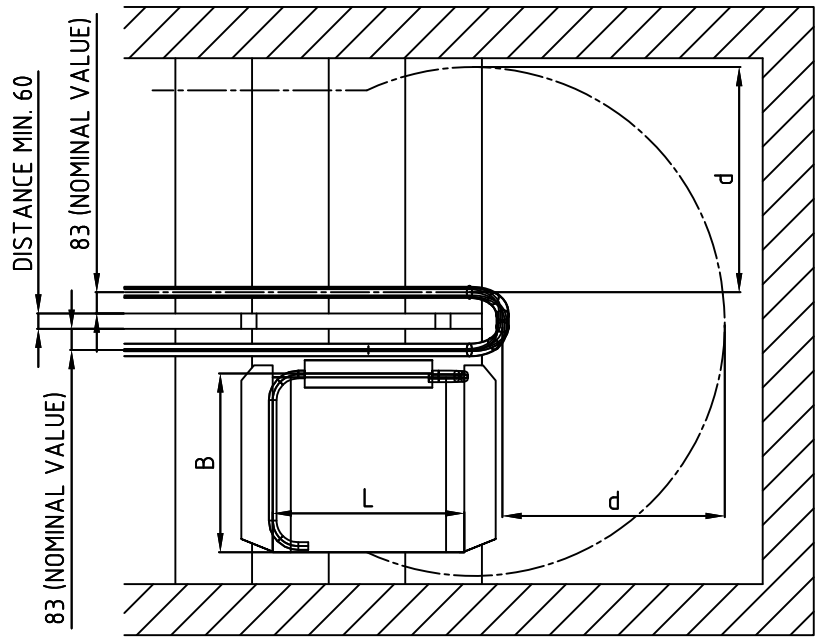
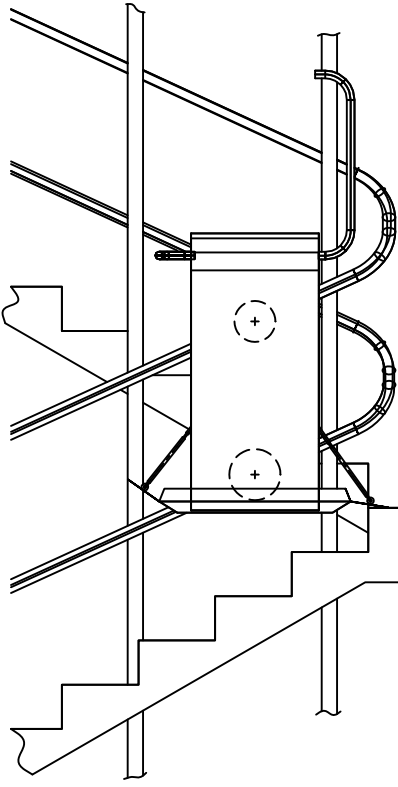

PRO MAXIMÁLNÍ STOUPÁNÍ 47°

150	994	1081	1044	1181	1069	1231	1119	1331	1232	1576	0,5 L + 619	L + 331
160	1003	1090	1053	1190	1078	1240	1128	1340	1241	1585	0,5 L + 628	L + 340
170	1012	1099	1062	1199	1087	1249	1137	1349	1251	1595	0,5 L + 637	L + 349
180	1021	1108	1071	1208	1096	1258	1146	1358	1258	1602	0,5 L + 646	L + 358
190	1030	1117	1080	1217	1105	1267	1155	1367	1267	1611	0,5 L + 655	L + 367
200	1039	1126	1089	1226	1114	1276	1164	1376	1277	1621	0,5 L + 664	L + 376
H 1. STEP HEIGHT	b	*c	b	*c	b	*c	b	*c	b	*c	b	*c
	L = 750		L = 850		L = 900		L = 1000		L = 1250		L = SPECIAL SIZE	

Waiver: This data sheet is for guidance only and must not be used for proper working drawings. Please contact supplier for particular details before proceeding. Owing to our policy of continual improvement we reserve the right to after specifications and dimensions without prior notice.

90° CURVE
WALL

IF NOMINAL VALUE IS SMALLER
THEN 81 MM, IN UPPER PIPE
SURROUNDING WALL EDGE
MUST BE CUTTED

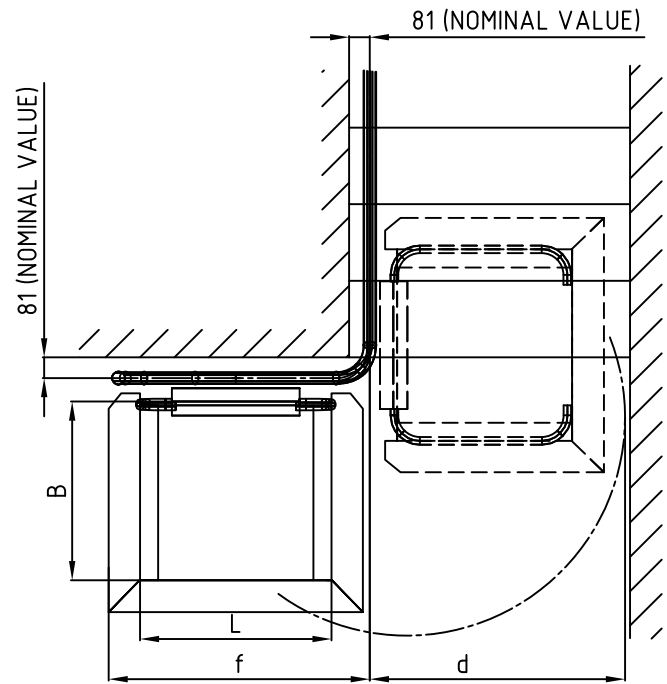
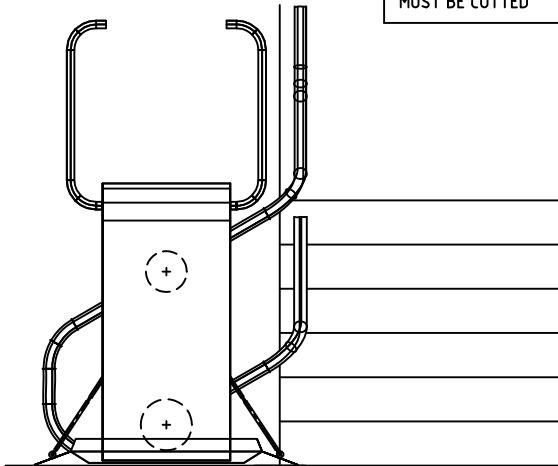

180° CURVE
WALL BETWEEN RAIL

IF NOMINAL VALUE IS SMALLER
THEN 81 MM, IN UPPER PIPE
SURROUNDING WALL EDGE
MUST BE CUTTED

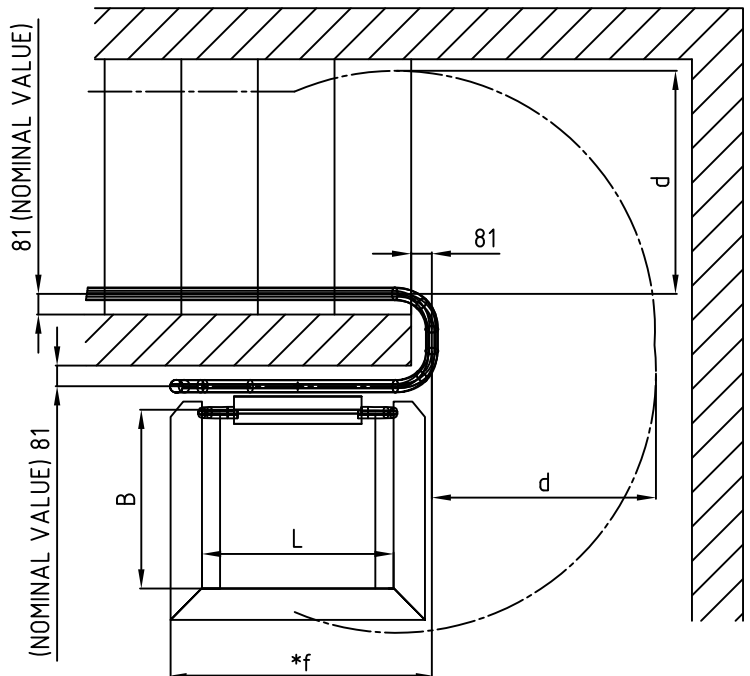
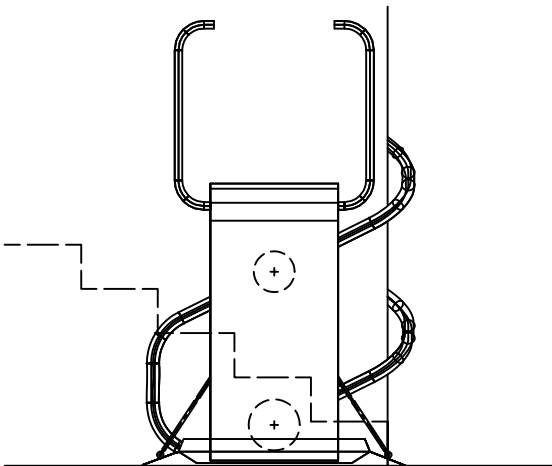

PLATFORM LENGTH L	ACCESS RAMPS	PLATFORM WIDTH B									*f
		600	640	670	700	740	770	800	900	1000	
		d									
750	200	789	823	848	874	909	935	962	1054	1149	1150
850	200	816	849	874	899	942	959	985	1074	1163	1250
900	200	832	864	889	914	947	973	998	1085	1174	1300
1000	200	862	894	918	942	975	1000	1023	1110	1197	1400
1250	200	930	960	985	1007	1046	1060	1085	1167	1251	1650

PLATFORM WITH FRONT RAMP 200mm

Waiver: This data sheet is for guidance only and must not be used for proper working drawings. Please contact supplier for particular details before proceeding. Owing to our policy of continual improvement we reserve the right to after specifications and dimensions without prior notice.